

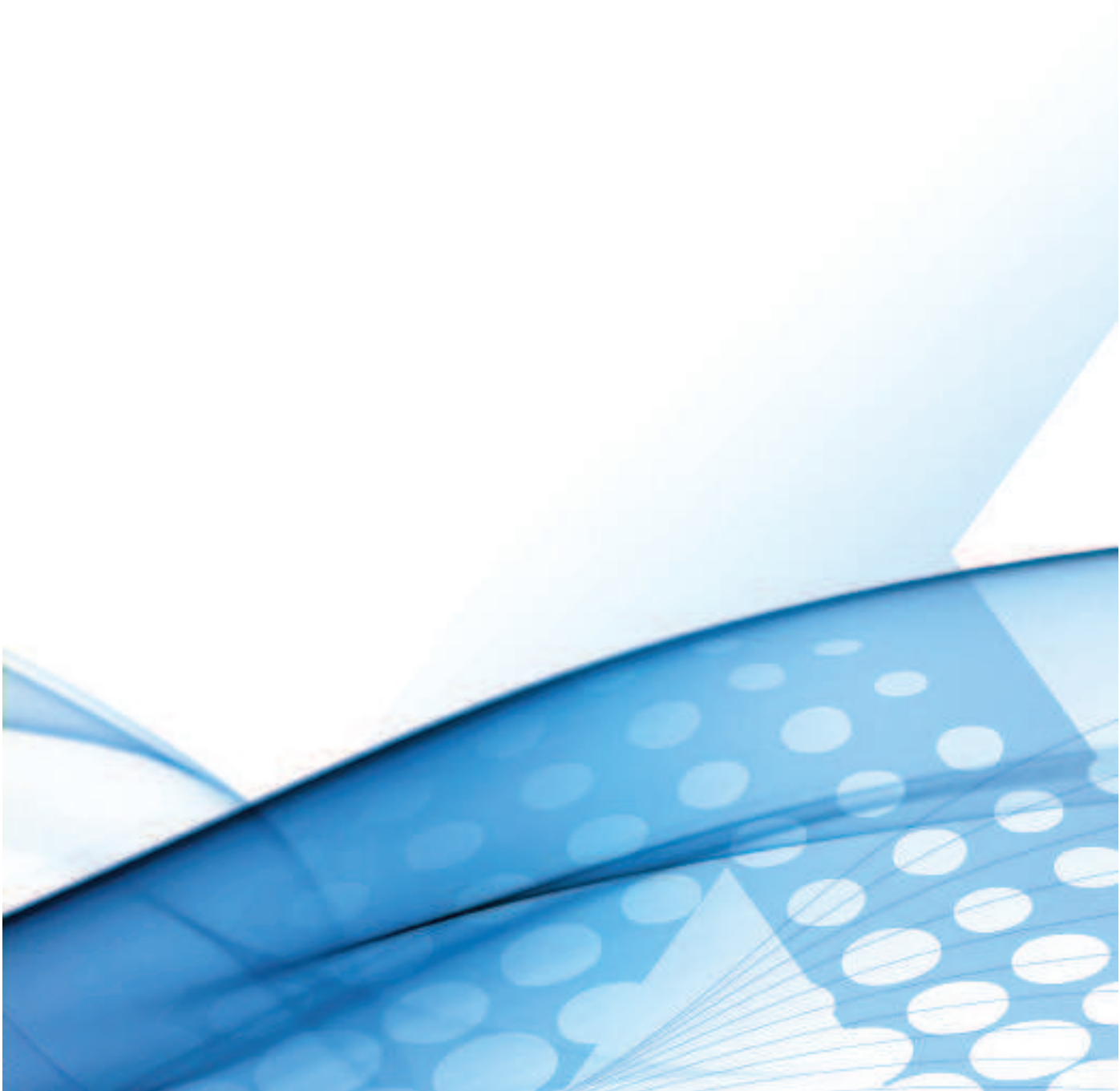

DATA SHEET

LitePoint iQnxxn™

MIMO Test Solution



Revision History

Release Date	Revision	Change Description
Jan 20, 2006	1.0	First Release
April 6, 2007	2.1	Updated with the latest information

Trademarks

Copyright © 2005-2007 LitePoint Corporation

All rights reserved. IQview, IQflex, IQnrxn, and IQmax are registered trademark and, IQsignal, IQwave, IQfact, IQcheck, IQdebug, IQmeasure, TrueChannel, TrueCable and LitePoint are trademarks of LitePoint Corp. Microsoft Windows is a registered trademark of Microsoft Corporation in the United States and/or other countries. All trademarks or registered trademarks are owned by their respective owners. The information furnished by LitePoint Corp. is believed to be accurate and reliable. However, no responsibility is assumed by LitePoint for its use. LitePoint reserves the right to change specifications and documentation at any time without notice.

Attention

LitePoint Corporation reserves the right to make changes in specifications and other information contained in this document without prior notice! LitePoint Corporation makes no warranty of any kind with regards to this material, including, but not limited to, the implied warranties of merchantability and fitness for a particular purpose. LitePoint shall not be liable for errors contained herein or for material or consequential damages in connection with the furnishing, performance, or use of this material.

LitePoint Corporation

575 Maude Court
Sunnyvale, CA 94085-2803
United States of America
Telephone: 1 408 456 5000
Facsimile: 1 408 456 0106
E-mail: support@litepoint.com
www.litepoint.com/support

IQnXn MIMO Test Solution

Introduction

The LitePoint IQnXn® MIMO Test Solution is optimized for the test needs of IC and product developers, QA, design verification and product evaluation implementing 802.11n draft.

Core to the IQnXn MIMO Test Solution is the array of synchronized VSA and VSG modules. The IQnXn MIMO Test Solution comes in a minimum 2x2 Starter System and can be expanded to 3x3 or 4x4 by adding IQnXn Expansion Units.

The included software includes the *IQsignal for MIMO* graphical user interface for analysis and generation of MIMO signals. Automated test programs can interface to the IQnXn MIMO Test Solution via a C++ or MATLAB compatible API. Complete compatibility with IQview R&D and IQflex manufacturing test systems for testing MIMO is accomplished with the inclusion of the MIMO manufacturing API.

The IQnXn MIMO Test Solution is compatible with LitePoint optional software products including the family of IQfact manufacturing test programs, Bluetooth Add-On Software and IQwave.

Application areas:

- Product Development
- Design Verification
- Quality Control
- Product Evaluation
- Performance evaluation and optimization.

Features :

- Synchronized VSA and VSG resources for testing MIMO devices
- Scalable from 2x2 to 4x4 configurations
- Easy to use through IQsignal for MIMO graphical user interface
- C++ and MATLAB API interfaces for automated testing
- Frequency ranges: 2.4GHz to 2.5 GHz, 4.9 to 6.0 GHz.
- Legacy WiFi support included
- Compatible with IQview and IQflex one box test instruments for high volume manufacturing
- Compatible with IQflex , Bluetooth and MIMO manufacturing test solutions
- Optional IQwave software for advanced VSG signal generation



Figure 1. IQnXn shown in a 4x4 configuration.

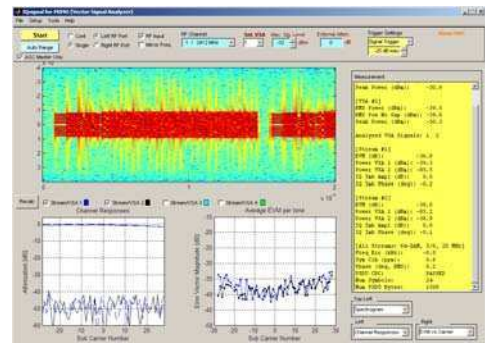

Figure 2. The IQsignal for MIMO analysis screen.

Functionality

IQnrxn is expressly designed to test the latest 802.11n MIMO WLAN products including network interface cards, access points, and embedded components. With the included software suite, 802.11a/b/g WiFi legacy devices can also be tested.

IQnrxn interfaces with the Device Under Test (DUT) through multiple VSA and multiple VSG subsystems synchronized to meet the requirements of multi-stream MIMO architectures. The basic configuration of the IQnrxn contains two VSA and two VSG subsystems for testing 2x2 (two transmitters with two receivers) architectures. The IQnrxn instrument can be expanded through the use of IQnrxn Expansion Units to 3x3 or 4x4 configurations.

The comprehensive software suite shipped with the instrument allows for testing of both MIMO and legacy WiFi products through an easy-to-use GUI or Application Program Interface (API) for laboratory automation or manufacturing test needs. The software automatically scales to the IQnrxn instrument configuration. The supplied manufacturing APIs enable compatibility to the highly successful IQview and IQflex One Box Test Instruments eliminating variations in test results from different test platforms.

IQnrxn supports testing in both the 2.4 GHz and 5 GHz frequency bands utilized worldwide for 802.11a/b/g/n products. Inputs and outputs at both RF and baseband are provided enabling detailed testing of all aspects of a WLAN product's analog design.

User Interfaces

For MIMO analysis, IQnrxn is bundled with the *IQsignal for MIMO™* Signal Analysis Software Suite, a powerful 802.11n analysis toolbox. Operating on a separate PC under the Windows® Operating System and connected to IQnrxn via TCP/IP over Ethernet, *IQsignal for MIMO* provides an intuitive graphical user interface that is easy to master. Users can interactively control and analyze IQnrxn measurements and operation either when connected to an IQnrxn instrument or off-line from saved captured waveforms.

To allow automated testing, IQnrxn includes the IQnrxn MATLAB compatible API and the IQnrxn C++ compatible API. These APIs support a complete IQnrxn command set and associated DLL files for the development of test programs. Whether used for product characterization during the development process or for quality assurance in manufacturing, the APIs support test setup, data capture, signal analysis, and result handling as well as general communications and error-handling functions. Supporting the popular IQview or IQflex test instruments, the IQnrxn can be used as a development platform for test program development.

To support 802.11a/b/g legacy products and to ensure compatibility with the installed base of IQview and IQflex instruments, LitePoint's 802.11a/b/g legacy IQsignal and IQview API are included with the IQnrxn software bundle.

VSA Operation

IQnrxn incorporates an array of 2, 3 or 4 VSA resources needed to test today's 802.11n multi-transmitter, multi-receiver devices. Legacy 802.11a/b/g devices, or MIMO devices operating in legacy modes, can also be analyzed with an IQnrxn instrument.

IQsignal for MIMO analyzes signals from MIMO devices using 802.11n signal formats. The software supports Modulation and Coding Schemes (MCS) 0 through 31 for 20 and 40 MHz bandwidth (including transmission in upper/lower 20 MHz of a 40 MHz channel) and HT duplicate for 40 MHz (MCS 32). Also, the 400 ns short guard interval mode and mixed mode and green field format analysis is supported. Furthermore, space-time block coding (STBC) for two space-time streams (one spatial stream) is supported.

IQsignal for MIMO measures the quality of the MIMO transmission and, if Direct Mapping is used, it associates the quality of each stream with the quality of each transmit chain.

IQsignal for MIMO offers advanced analysis options that expand standard 802.11n analysis beyond simple power, EVM, or spectral measurements. For example, *IQsignal for MIMO* can easily analyze frequency settling and phase noise that occurs during a burst transmission. Such capabilities significantly help in understanding and debugging RF performance-related issues.

IQsignal for MIMO supports 802.11n analysis of all in-band transmitter specifications required for compliance with the IEEE 802.11n standards. *IQsignal for MIMO* provides a graphical display of these tests for each transmitter including:

- spectral mask
- symbol constellation (including EVM measurements)
- carrier leakage
- spectral flatness (for 802.11a/g OFDM signals)
- channel response (transmitter isolation)
- power vs. time

To support product debugging, various other graphical displays are supported by *IQsignal for MIMO* including:

- phase noise (power spectral density versus time)
- CCDF (to support compression analysis)
- spectrogram
- EVM versus OFDM subcarriers versus time

Besides the graphical display of VSA measurements, *IQsignal for MIMO* also presents relevant numerical data including:

- EVM per stream
- power (peak, average) per stream and per VSA
- I/Q amplitude imbalance per stream when in Direct Mapping mode
- I/Q phase imbalance per stream when in Direct Mapping mode
- frequency error per DUT
- symbol timing error per DUT
- integrated phase noise per DUT

IQsignal for MIMO additionally provides a wide range of compensation methods that can be used for advanced analysis of a captured signal's sensitivity to certain impairments. For example, the available compensation methods when analyzing OFDM signals include:

- phase tracking (off, on)
- channel estimation (based on averaging of the long training sequence or averaging of the full packet)
- symbol timing tracking (off, on)
- frequency synchronization

IQsignal for SISO analysis can also be run on the IQnrxn using a single VSA/VSG chain providing legacy 802.11a/b/g analysis capabilities. See the IQview datasheet for more details.

VSG Operation

IQsignal for MIMO also controls the IQnrxn VSG resources. The user can select among various pre-defined test signals, adjusting the transmit frequency, the output power, and whether the transmitter should operate continuously or only transmit a specific number of packets.

IQwave – An Optional Software Tool

To simplify the generation of arbitrary 802.11a/b/g/n waveforms, LitePoint offers an optional PC-based tool, the *IQwave*™ WLAN Waveform Generator Software. With *IQwave*, the user can specify one or more complete packets as well as introduce impairments such as noise, fading, and frequency offset. The generated signals can then be loaded for transmission by IQnrxn by using the *IQsignal* VSG control interface.

IQwave provides a simple GUI to specify the type of 802.11a/b/g/n transmit packets to be generated. The user can specify the contents of the MAC header (e.g., the MAC address and SSID) as well as the actual payload data. As desired, *IQwave* then allows impairments to be introduced to the signal, including noise (a specific E_b/N_0), I/Q imbalances, frequency offsets, and channel models. For 802.11a/b/g signals the ETSI Hiperlan/2 multipath channel models are available. For 802.11n signals, the TGn channels are available. User can also define custom channels for all 802.11 modes.

All mandatory rates for 802.11a/b/g are supported. For 802.11n Modulation Control Sequence, or MCS, 0 through 31 are supported in 20 and 40 MHz mode and with direct and spatial mapping.

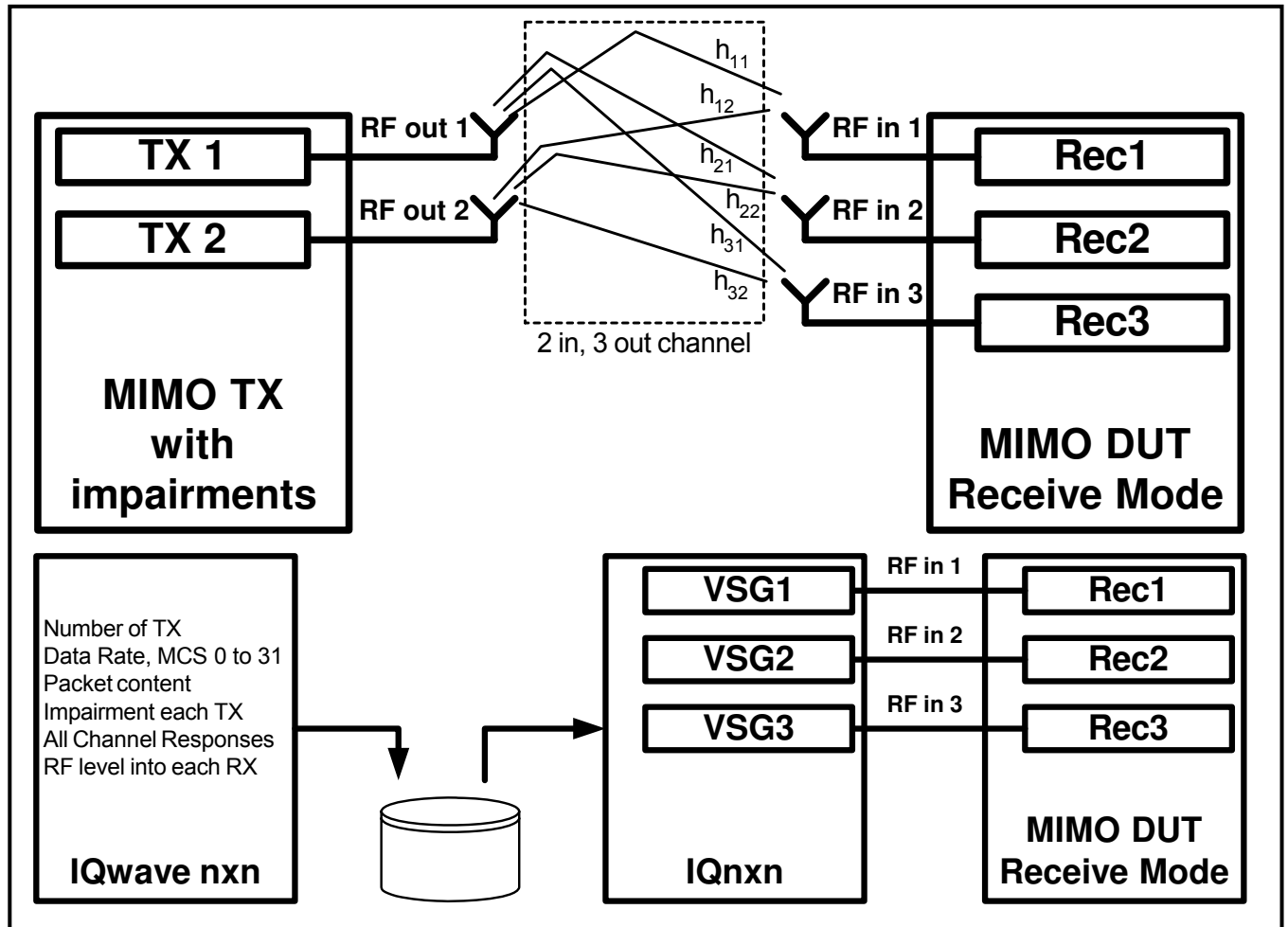

Figure 3. Example of how *IQwave* and *IQnxn* can be used to generate impaired signals into DUT receivers. RF1 into receiver 1 is the same in both configurations. The same applies to RF2 and RF3.

Please contact LitePoint for more information about *IQwave*.

IQnxxn Functional Block Diagram

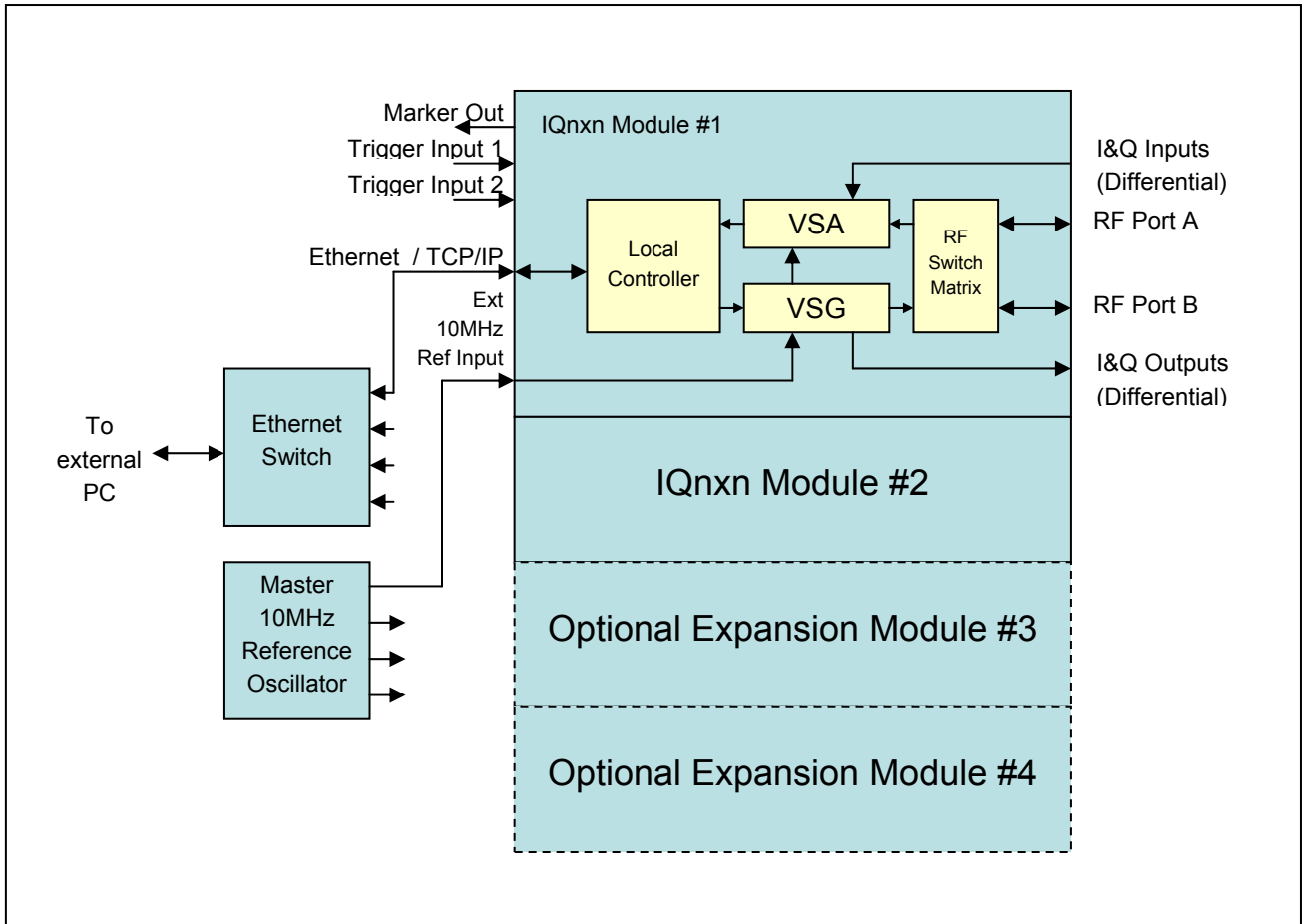

Figure 4. Basic block diagram of the IQnxxn instrument

IQnrxn Control and Synchronization

Several synchronization, reference, and control signals are needed to have the multiple VSA and VSG resources of an IQnrxn Instrument operate as a single unit. The various input and output signals are supplied to support the ability to expand an IQnrxn instrument from the minimum 2x2 (two VSA and two VSG resources) to a maximum of 4x4. Details of the connection of these signals are included in the IQnrxn Quick Start Guide shipped with each instrument.

VSA Signal Parameters (User Interface)

- | | |
|------------|---|
| RF channel | <ul style="list-style-type: none"> RF channel selection sets both VSA and VSG hardware user-defined center frequency (within 2400-2500 MHz or 4900-6000 MHz with 1 MHz resolution) selectable pre-programmed center frequencies: |
|------------|---|

channel number / center frequency (MHz)					
1 / 2412	9 / 2452	00 / 4980	52 / 5260	116 / 5580	153 / 5765
2 / 2417	10 / 2457	00 / 5040	56 / 5280	120 / 5600	157 / 5785
3 / 2422	11 / 2462	00 / 5080	60 / 5300	124 / 5620	161 / 5805
4 / 2427	12 / 2467	00 / 5100	64 / 5320	128 / 5640	00 / 5825
5 / 2432	13 / 2472	36 / 5180	100 / 5500	132 / 5660	00 / 5865
6 / 2437	14 / 2484	40 / 5200	104 / 5520	136 / 5680	00 / 5885
7 / 2442	00 / 4920	44 / 5220	108 / 5540	140 / 5700	00 / 5905
8 / 2447	00 / 4940	48 / 5240	112 / 5560	149 / 5745	00 / 5945

The gain control of the VSA units can either be independent or controlled by the master VSA.

Captures from each VSA unit are synchronized to occur within one 80 MHz sample. The trigger of the master unit can be set to free run, external, or RF power. The trigger of the slave units is controlled by the master.

VSA Performance (per VSA/ VSG module)

frequency	<ul style="list-style-type: none"> 2400 - 2500 MHz 4900 - 6000 MHz
analog bandwidth	60 MHz (\pm 30 MHz quadrature)
quantization	14 bits
sampling frequency	80 MHz at the ADC
sampling resolution	1 sample
acquisition buffer	2^{20} samples (~1,000,000 samples)
pre-trigger capture	$(2^{20} - 1)$ samples (~1,000,000 samples)
sampling filter amplitude variation	\leq 0.25 dB (0 – 10 MHz offset frequency)
sampling filter group delay variation	\leq 300 ps (0 – 10 MHz offset frequency)
RF port	
noise figure	\leq 25 dB
input amp level	-25 to +23 dBm
power measurement accuracy	<ul style="list-style-type: none"> specification: \pm 1.0 dB typical: \pm 0.5 dB
residual EVM	<ul style="list-style-type: none"> VSA contribution to measurement of 802.11a/g/n OFDM signals input power \geq -35 dBm Specification: \leq -35 dB (\leq 1.78%) Typical: -41 dB (0.89%)

SNR	<ul style="list-style-type: none"> VSA contribution to measurement of 802.11b/g DSSS signals input power ≥ -10 dBm 100 kHz resolution BW specification: ≥ 55 dB typical: 60 dB
spurious response	<ul style="list-style-type: none"> 802.11b/g DSSS signals measured w.r.t. spectral mask out-of-band: ≤ -45 dB in-band: ≤ -55 dB with 100 kHz resolution BW
amplitude flatness	≤ 0.2 dB (0 – 10 MHz offset frequency)
integrated phase noise	typical: 0.5 degrees (100 Hz – 1 MHz)
input return loss	≥ 10 dB

All performance specified at 25°C

VSG Signal Parameters (User Interface)

- RF channel
- RF channel selection sets both VSA and VSG hardware
 - user-defined center frequency
(within 2400-2500 MHz or 4900-6000 MHz with 1 MHz resolution)
 - selectable pre-programmed center frequencies:

channel number / center frequency (MHz)					
1 / 2412	9 / 2452	00 / 4980	52 / 5260	116 / 5580	153 / 5765
2 / 2417	10 / 2457	00 / 5040	56 / 5280	120 / 5600	157 / 5785
3 / 2422	11 / 2462	00 / 5080	60 / 5300	124 / 5620	161 / 5805
4 / 2427	12 / 2467	00 / 5100	64 / 5320	128 / 5640	00 / 5825
5 / 2432	13 / 2472	36 / 5180	100 / 5500	132 / 5660	00 / 5865
6 / 2437	14 / 2484	40 / 5200	104 / 5520	136 / 5680	00 / 5885
7 / 2442	00 / 4920	44 / 5220	108 / 5540	140 / 5700	00 / 5905
8 / 2447	00 / 4940	48 / 5240	112 / 5560	149 / 5745	00 / 5945

- RF Level
- The level of each VSG unit can be set independently within the range specified by RF Port Output level (See VSG Performance RF Port specification)

VSG Performance (per VSA/ VSG module)

frequency	<ul style="list-style-type: none"> 2400 - 2500 MHz 4900 - 6000 MHz
analog bandwidth	70 MHz (± 35 MHz quadrature)
quantization	14 bits
sampling frequency	80 MHz
sampling resolution	1 sample
waveform length	2^{20} samples (~1,000,000 samples)
pre-trigger capture	$(2^{20} - 1)$ samples (~1,000,000 samples)
DAC filter amplitude variation	typical: ≤ 0.25 dB (0 – 20 MHz offset frequency)
DAC filter group delay variation	typical: ≤ 400 ps (0 – 20 MHz offset frequency)
RF port	output level
	<ul style="list-style-type: none"> 2400 – 2500 MHz: -95 to 0 dBm 4900 – 6000 MHz: -95 to -10 dBm
	power accuracy
	<ul style="list-style-type: none"> specification: ± 1.0 dB typical: ± 0.6 dB

EVM	<ul style="list-style-type: none"> • 2400 – 2500 MHz <ul style="list-style-type: none"> – 802.11a/g/n OFDM signals <ul style="list-style-type: none"> ❖ ≤ -38 dB (output level: -95 to -10 dBm) ❖ ≤ -35 dB (output level: -10 to -5 dBm) – 802.11b/g DSSS signals: ≤ -30 dB (output level: -95 to 0 dBm) • 4900 – 6000 MHz <ul style="list-style-type: none"> – ≤ -38 dB (output level: -95 to -15 dBm) – ≤ -35 dB (output level: -15 to -10 dBm)
SNR	<ul style="list-style-type: none"> • 802.11b/g DSSS signals only • 100 kHz resolution BW • specification: ≥ 55 dB • typical: 70 dB
undesired sideband	≤ -45 dBc (0.1 – 10 MHz; CW output)
carrier leakage	≤ -45 dBc (CW output)
spurious	<ul style="list-style-type: none"> • specification: ≤ 50 dBc (in-band) • typical <ul style="list-style-type: none"> – ≤ -20 dBc out-of-band (harmonics) – ≤ -35 dBc out-of-band (non-harmonic)
integrated phase noise	typical: 0.5 degrees (100 Hz – 1 MHz)
output return loss	≥ 10 dB

All performance specified at 25°C

Master Reference Oscillator

Frequency	10.000MHz
Initial Accuracy	0.3ppm
Short Term Accuracy (1sec)	<1x10 ⁻¹²
Aging	0.07ppm over 1 year operation
Temperature	0.02ppm pk to pk over instrument operating temperature range

User Accessible Interfaces

Front Panel	RF input/output	SMA female	<ul style="list-style-type: none"> • RF signal (auto configured to input or output) • 50 Ohms • +20dBm maximum input level, AC signal only • ESD sensitive ports, use in an ESD safe environment only • Supports both 2.4-2.5GHz and 4.9-6.0 GHz bands
	Power	Soft Switch	<ul style="list-style-type: none"> • on/off power switch
Rear Panel	10/100 Mbps Ethernet	RJ-45	TCP/IP connectivity
	AC in	15A IEC connector	<ul style="list-style-type: none"> • for use with country-specific cord and plug • 90–132 VAC or 198-264 VAC (automatically switched) • 47–63 Hz
	Power	Rocket Switch	<ul style="list-style-type: none"> • on/off <p>Note: Not recommended for use.</p>

Physical & Environmental

dimensions	42" H x 24" W x 36" D
weight	<ul style="list-style-type: none">• Each RF Signal Processing Instrument - 8.2 kg (18 lb)• Channel Emulation Instrument – 8.2 kg (18 lb)• Rack and miscellaneous - 22.7 kg (50 lb)• 3x3 configured system – 55.5 kg (122 lb)• 4x4 configured system – 63.3 kg (140 lb)
power consumption	<ul style="list-style-type: none">• 300W max each internal instrument• 1200W max for 3x3 configured system• 1500W max for 4x4 configured system
operating temperature	0°C to +55°C (IEC 68-2-1, 2, 14)
storage temperature	-40°C to +70°C (IEC 68-2-1, 2, 14)
operating humidity	15% to 95% relative humidity, non-condensing (IEC 68-2-30)
recommended calibration cycle	12 months
warranty	12 months hardware and software updates

Regulatory & Compliance Information

EMI compatibility	<ul style="list-style-type: none">• 89/336/EEC revised by 91/263/EEC, 92/31/EEC, 93/68/EEC• EN55011/ CISPR 11: 1998 + A1+A2• EN61326-1: 1997 + A1 + A2• FCC Part 15 Class A / 04.99• IC CS003
Safety	<ul style="list-style-type: none">• 73/23/EEC revised by 93/68/EEC• EN61010-1: 1993 + A2: 1995• UL 61010A R4.02• CAN/CSA c22.2 No. 1010

Shipping Contents

IQnxn instrument	Starter system contains two units. Expansion unit contains one unit.
IQnxn Software CD	
Master Reference Oscillator Module	Includes AC power adaptor module
Ethernet Switch	
Documentation Envelope	Includes Quick Start Guide, Calibration Certification Certificates, Warranty Statement
Cables	AC power cables, Ethernet cables, BNC cables
Misc.	RF loopback adaptors, Rack mount brackets, Instrument handles with rear spacers

PC System Requirements

PC	Intel Pentium processor or compatible
operating system	Microsoft Windows 2000; Windows XP Professional; Windows XP Home Edition
memory	≥ 256MB of RAM
disk space	≥ 200MB of available hard disk space
monitor	at least 1024 x 768 resolution
connectivity	TCP/IP over 10/100BaseT Ethernet

Order Information

IQNXNSS LitePoint IQnxn Starter System (2x2 configuration)

Optional Accessories

IQXNEU	LitePoint IQnxn Expansion Unit
IQNXNSS-XWR	IQnxn Starter System 1 year extended warranty and updates. Includes one annual calibration
IQXNEU-XWR	IQnxn Expansion Unit 1 year extended warranty and updates. Includes one annual calibration
IQNXNSS-CAL	IQnxn Starter System Annual Calibration
IQNXNSS-CAL/PP	IQnxn Starter System Annual Calibration – Prepayment option
IQXNEU-CAL	IQnxn Expansion Unit Annual Calibration
IQXNEU-CAL/PP	IQnxn Expansion Unit Annual Calibration – Prepayment option
IQWAVE	IQwave including MIMO support
IQWAVE-XWR	IQwave including MIMO support - 1year extended software updates
(Consult factory)	IQfact Manufacturing Test Programs for MIMO and Legacy Chip Sets. Consult factory for latest product availability.

LitePoint Corporation

575 Maude Court, Sunnyvale, CA 94085
+ 1.408.456.5000 www.litepoint.com

IQview, IQflex, IQnxn, and IQmax are registered trademark and, IQsignal, IQwave, IQfact, IQcheck, IQdebug, IQmeasure, TrueChannel, TrueCable and LitePoint are trademarks of LitePoint Corp. All other trademarks are the property of their respective owners. The information furnished by LitePoint Corporation is believed to be accurate and reliable. However, LitePoint assumes no responsibility for its use. LitePoint reserves the right to change specifications and documentation at any time without notice. Copyright © 2006-2007 LitePoint Corporation. 04/07